



SPECIFICATION OF PRODUCT

CUSTOMER: _____

DESCRIPTION : SPEAKER

EKEYSOUND P/N: EKS5011

CUSTOMER P/N: _____

DATE : 2018-06-23

Specification for speaker

1. CONDITION.

Test and measurement will be carried out under normal condition of temperature within 5°C to 35°C, relative humidity within 45% to 85% and air pressure of 860 mbar to 1060 mbar.

Should uncertainly arise in data obtained from the above atmosphere, control of temperature

at 20°C±2°C and relative humidity within 60%and 70%, with air pressure remaining unchanged, to be enforced.

2. ELECTRICAL AND ACOUSTICAL SPECIFICATION.

2-1	Rated Input Power.	0.5W.
2-2	Max Input Power.	1.0W
2-3	Rated Impedance.	8Ω ± 15%
2-4	Sound Pressure Level. (S.P.L)	90dB(0.1W/0.1m) ± 3 dB at AVE 0.8K 1.0K 1.2K 1.5K Hz
2-5	Resonance Frequency (Fo).	500±20%Hz
2-6	Frequency Range.	F0~10kHz.
2-7	Distortion	Less than 5% at 1KHz input Rated Power
2-8	Magnet	Rare earth permanent (NdFeB) magnet Φ12.5*1.5mm
2-9	Buzz, Rattle, etc.	Should not be audible at 2.0V sine Wave between Fo to 20KHz
2-10	Polarity	When positive voltage is applied to the terminal marked (+), diaphragm should move to the front.
2-11	Appearance	Should not exist any obstacle to be harmful to normal operation; damages, cracks, rusts and distortions, etc.
2-12	Weight.	g
2-13	Temperature	Operating temperature: -20°C to +60°C Storage temperature: -30°C to +70°C

Specification for speaker

3. MEASURING METHOD

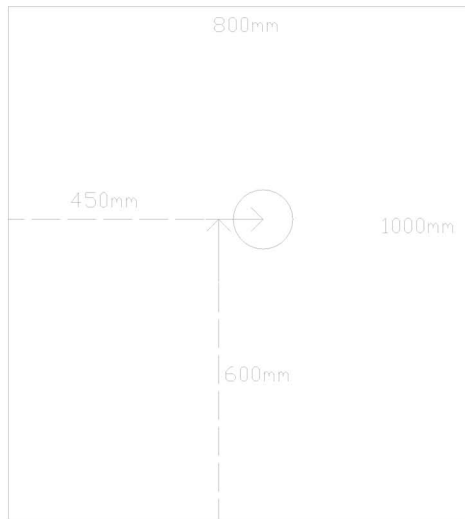

FIG.1

3.1 Block Diagram For Measurement Method.

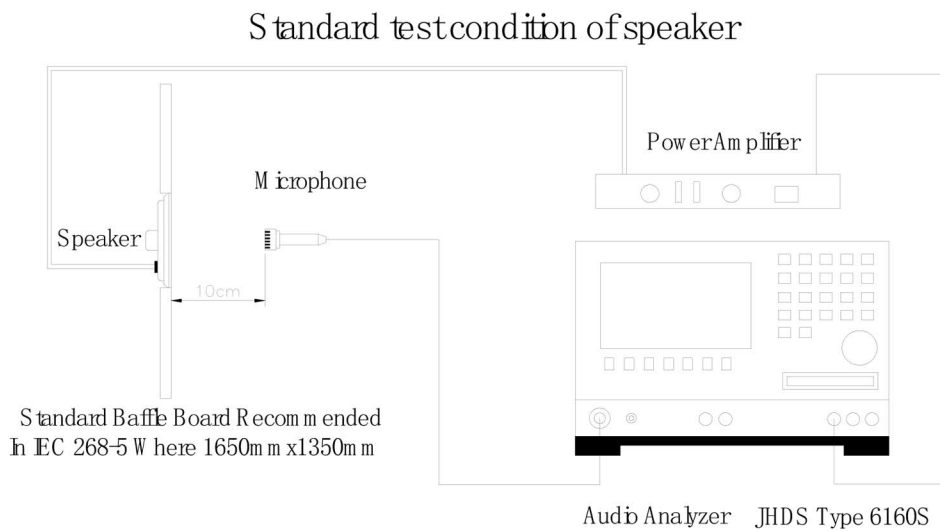

FIG.2

Specification for speaker

4. Frequency Response :

The swept sine-wave frequency response of a Loud speaker should ideally not deviate more than indicated per Fig.3

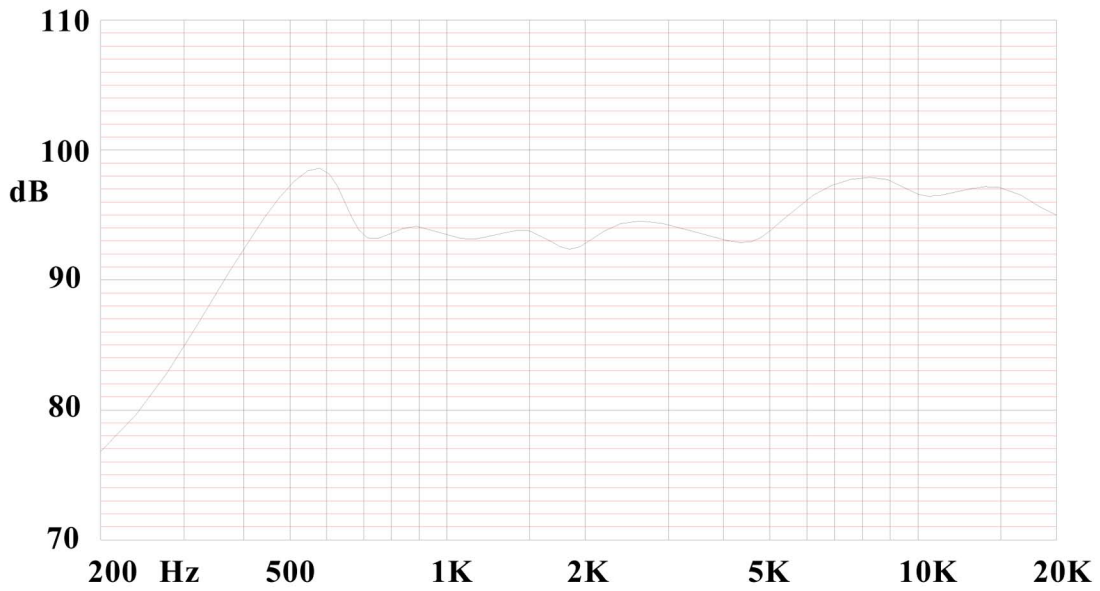
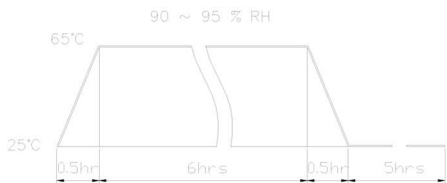

FIG.3

Specification for speaker

5. ENVIRONMENT TEST

ITEM		SPECIFICATIONS
01	High temp. Test	Keep 96 hours at $+70\text{ }^{\circ}\text{C} \pm 3\text{ }^{\circ}\text{C}$ and leave 6 hours in normal temperature and then check
02	Low temp. Test	Keep 96 hours at $-30\text{ }^{\circ}\text{C} \pm 3\text{ }^{\circ}\text{C}$ and leave 6 hours in normal temperature and then check
03	Humidity test	Keep 96 hours at $+40\text{ }^{\circ}\text{C} \pm 3\text{ }^{\circ}\text{C}$ relative humidity 92-95% and leave 3 hours in normal temperature and then checked.
04	Temp./Humidity cycle	<p>The part shall be subjected 5 cycles. One cycle shall be 6 hours and consist of;</p> 
05	Vibration	10~55~10Hz sin-wave sweep 15min. 5G(constant) X,Y, Z 3 direction. 2 hours each, total 6 hours.
06	drop test	Drop the speakers contained in normal box onto the board 40mm thick 10 times from the height of 75cm
07	Load test	Rate Power white noise is applied for 96hours at room temp
08	Lead Wire Pull Strength	<p>The pull force shall be applied to double lead wire :</p> <p>Horizontal 3.0N(0.306kg) for 30 seconds.</p> <p>Vertical 2.0N(0.204kg) for 30 seconds.</p>

Criterion :

After these test , the change of S.P.L shall be within $\pm 3\text{ dB}$

Specification for speaker

6.Dimensions

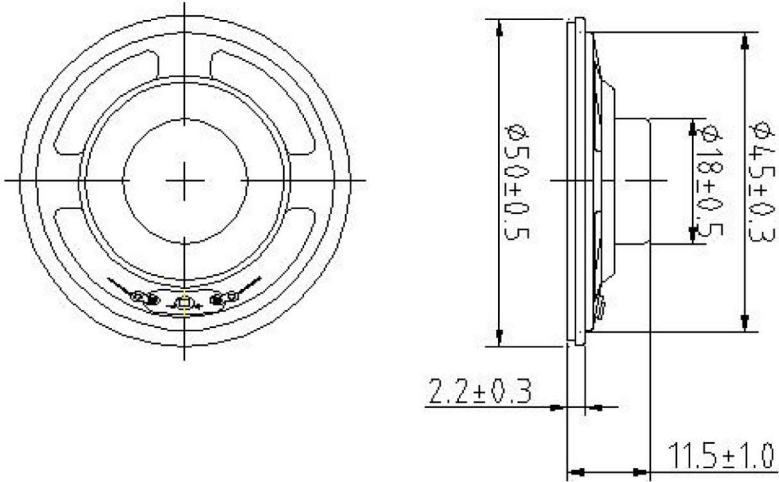

Unit:mm Tol: ± 0.5

7	Gasket	1	Paper	
6	Diaphragm	1	Paper	
5	VOICE COIL	1	Paper+Cu	
4	Plate	1	SPCC	
3	Magnet	1	NdFeB	
2	PCB Terminal	1	FR4	
1	Frame	1	Spcc	
The material must be meet to GU-001				
PART NO.	PART NAME	Q'TY	MATERIAL	REMARK

Specification for speaker

7.Packing

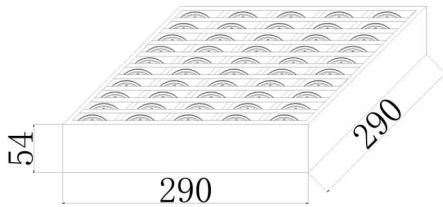

- 1.Each clapboard 100pcs,
Each carton 5 clapboards,
500pcs/carton

N.W: 8 KG, G.W:11 KG

- 2.Corrugated paper: 290*290mm 1 pcs
- 3.Inner Carton size: 305*305*305mm 1 pcs
- 4.Outer Carton size: 325*325*335mm 1 pcs

